

DAC using SPI Controller

Functional Description:

The controller designed covers the digital data into analog, where the digital data is transferred using SPI Controller and DAC (LTC 2624) converts the serial data into the analog. SPI Controller controls the speed, data transmission, DAC selection etc. Based on the inputs from the SPI line, DAC(LTC 2624) converts the 12 bit data to analog.

Features:

- Converts any 12 bit digital data into analog form
-

- Analog output voltages vary from 0-3.3V based on input digital values
- Converts digital data stored in Ram or from I/O, into analog form continuously
- SPI provides 4 wire interface to the DAC
- DAC supports 24-bit and 32-bit protocol
- The 24 or 32 bit command word consists of a command, an address, followed by data value
- The bus slave i.e, DAC provides serial data back to the SPI master
- It supports clock frequency rates up to the maximum of 50 MHz

Symbol:

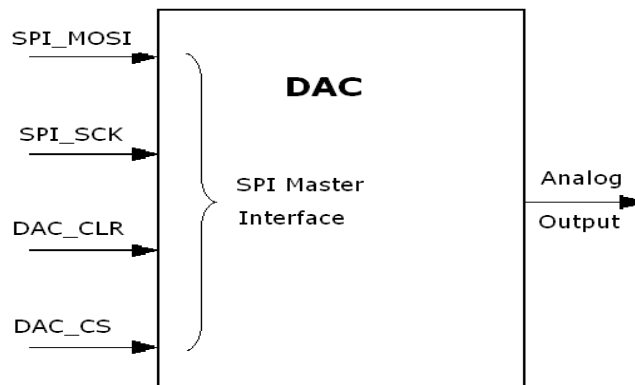

Pin Descriptions:

<i>Pin</i>	<i>Type</i>	<i>Description</i>
SPI_MOSI	Input	SPI Master Output as a input to DAC
DAC_CS	Input	Active low chip select signal
SPI_SCK	Input	SPI clock input
DAC_CLR	Input	Asynchronous, active low reset input
DAC_OUT	Input	Serial data from the DAC
Analog Output	Output	Analog output from DAC

Block Diagram:

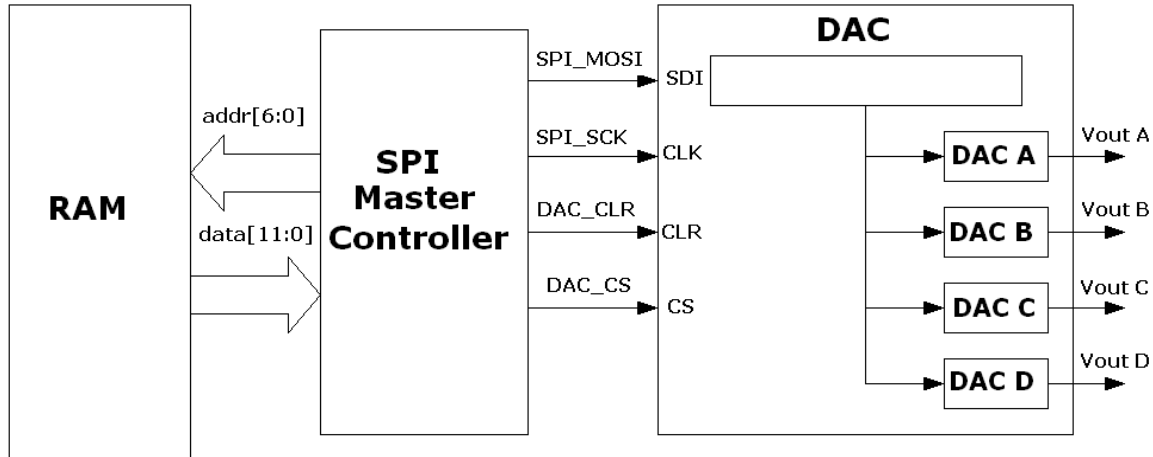

SPI Master Controller:

SPI controller block generates the SPI master output signals for the digital 12 bit values. SPI Controller continuously sends the data to the SPI bus by reading the stored data in the RAM. The SPI bus is a full-duplex, synchronous, character-oriented channel employing a simple four-wire interface.

RAM:

RAM block is used to store the data. It sends the data to the SPI Controller corresponding to the input address from the Controller.

DAC:

DAC block has four DAC's embedded in it. The SPI Controller sends 32 bit sequence which includes 12 bit data, 4 bit command, 4 bit address

with 12 don't care bits. Based on address, particular DAC is selected and 12 bit digital value is converted to analog.

Verification:

The SPI Master Controller with DAC has been verified with following approaches:

- Exhaustive functional and timing verification.
- Prototyped on Spartan-3A board and verified by observing analog output waveforms on the oscilloscope

Deliverables:

Verilog RTL source code
Test benches
Synthesis and Simulation scripts